

**INDAG-dynamic inline mixer
Type DLM HY
Hygienic execution
For food industry**

INDAG
Maschinenbau GmbH

The FlowMix®-Company



Dynamic mixers
for the continuous mixing of liquids

Applications for INDAG-DLM HY mixer

- Dairy & Beverage Industry (milk, quark, yoghurt, cheese, tzatziki, cream,...)
- Bakery (sponge cake, waffle, dough, ...)
- Sweets (chocolate, candy, snacks,...)



Advantages of INDAG DLM HY mixer

Mixer-housing

The mixer housing consists of thick-walled steel.

Thus the mixer is from high stability and can be inserted as attachment point for pipings.

The static o-rings are squeezed in way that there is no gap between o-ring and metal surface.

The connections are milled and allowed a formed welding. The mixer can be positioned horizontal or vertical. In each position mixer is self-draining.

The surface in contact with product has a quality of RA 0,8 and is polished. Mixer housing is designed without dead spaces and free of gaps.

Mixer-Rotor

The rotors are available with different mixing elements and geometries.

The rotor is hold by a single side bearing outside of product room.

Rotor can be dismounted easielly.

Seal

Single- and double acting mechanical seal is in cartridge execution. The seal is pressure-reversible.

CIP/ SIP cleaning

All INDAG-mixers are CIP/ SIP cleanable. All materials including elastomers (o-ring) with stand CIP/ SIP fluids like acids solutions and caustic lye.



Horizontal installation position



Vertical installation position

Types of mixing elements

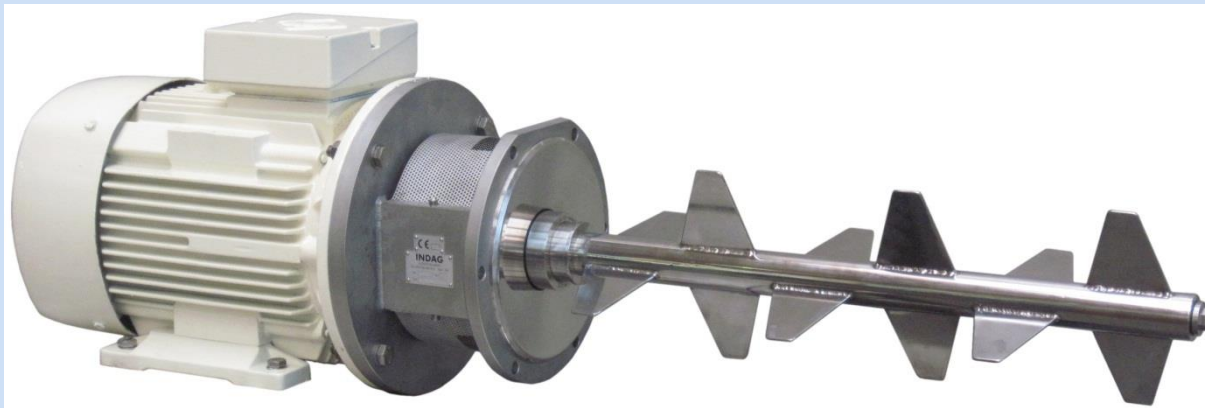

Hook shape mixing element

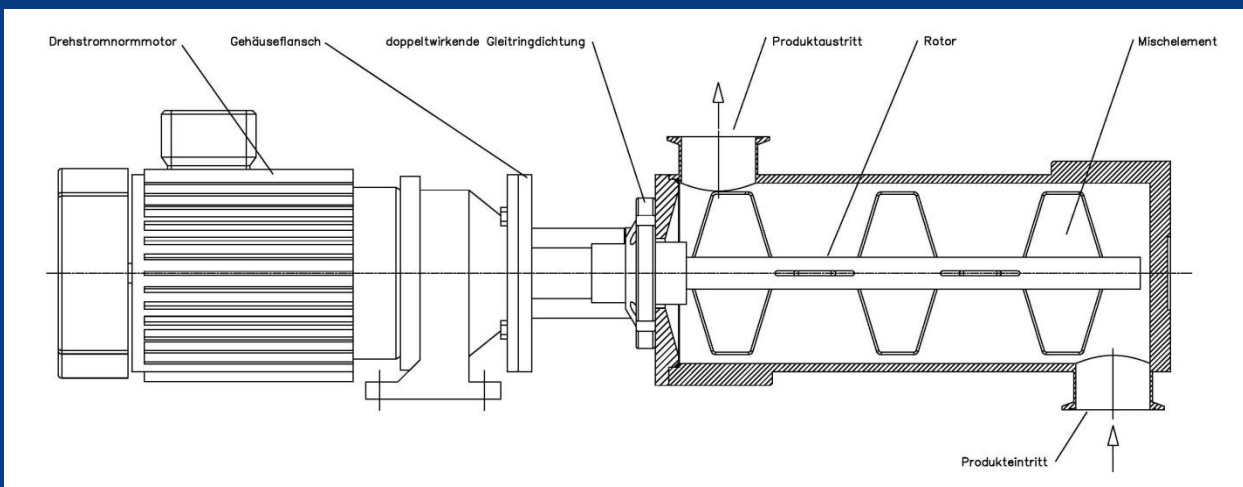

Trapez shape mixing element

Options for INDAG-Inline Mixer type DLM HY

- Single and double bearing
- Optional jacket for heating and/or cooling
- Single or double acting mechanical seal
- Wide range of material options
- Different mixing elements for different mixing characteristics

DLM HY mixer with own bearing block mounted on foundation plate. Motor with housing



DLM AS mixer in aseptic execution

Technical data of INDAG Mixer type DLM HY

Type		DLM-0	DLM-1	DLM-2	DLM-3	DLM-4	DLM-5
Max. capacity	l/h	500	2.000	5.000	13.000	23.000	40.000
connections	DN	25	40	50	65	80	100
connections	inch	1"	1 1/2"	2"	2 1/2"	3"	4"
Power	kW	0,55	0,75	1,1	1,5	3	5,5

*the capacity depends on product and mixing ratio

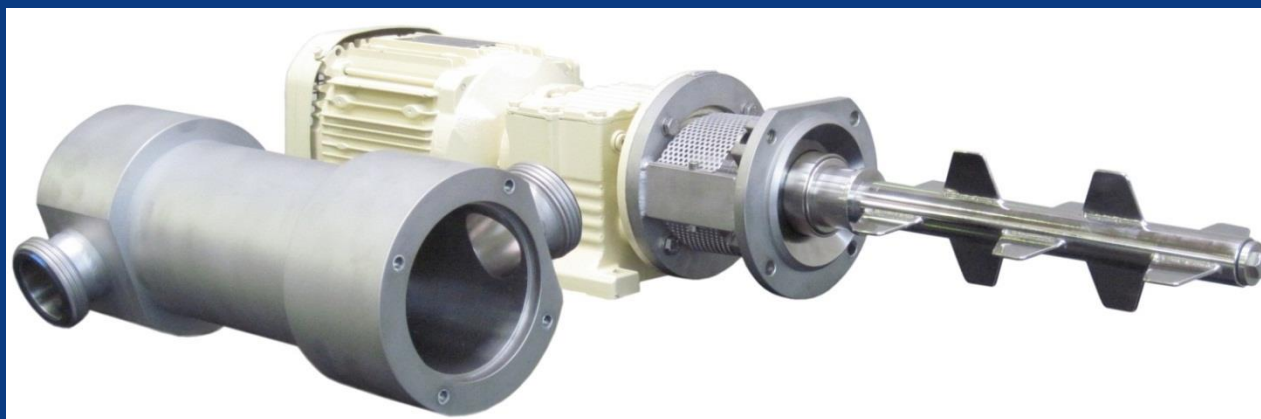

Technical details

Capacities

10 liter/hr to 120.000 liter/hr
3 gallon/hr to 32.000 gallon/hr
Higher capacities on inquiry

Pressure levels

Up to 25 bar = 362 PSI
Higher pressure rating on inquiry
In accordance with directives on pressure vessels

Positioning

Horizontal or vertical positioning possible.

Connecting point positions

Standard position:
Inlet axial on face side; Outlet radial in 12 o'clock on drive side

Cleaning

Hygienic version HY is especially free of inaccessible areas.

Materials

1,4301 (AISI 304)
1,4404 (AISI 316 L)

Seals

Single-action floating ring seal (mechanical seal)
Double-action floating ring seal (mechanical seal)
Other seals possible

Viscosity

From 1mPas to 2.000.000mPas

Temperature

Up to 200 °C
Higher temperatures on inquiry

Connections

Dairy screw thread DIN 11851, DIN 11864, Tri clamp to DIN 11851 SMS, Other connections on inquiry

Drives

Several Voltages, 50 or 60 Hz
IEC, DIN, ISO, VDE, EN
API, AEIC, IES, IEEE, ICEA, NEMA
Explosion proof EEx, ATEX



Contact

INDAG
Maschinenbau GmbH

Distributore Italiano:

FOIN Impianti Industriali s.r.l.
Zona Ind.le Campolungo (2 Fase)
63100 ASCOLI PICENO
Tel. 0736 814550

info@foin.it
www.foin.it

