

Horizontal self-priming centrifugal pumps

Your choice of any pump should be a well considered act, not to be left to pure chance.

Your choice of a DESMI self-priming centrifugal pump holds out the advantages of versatility and sturdiness. Once the pump casing has been filled with water, the pump will be self-priming, i.e. it will automatically remove the air in the suction pipe using the diffuser principle. Another feature is the ability of the pump to carry impurities and solids along with the actual fluid. This is due to the open impeller design including a replaceable wear plate, as distinct from closed impeller design of other centrifugal pumps.

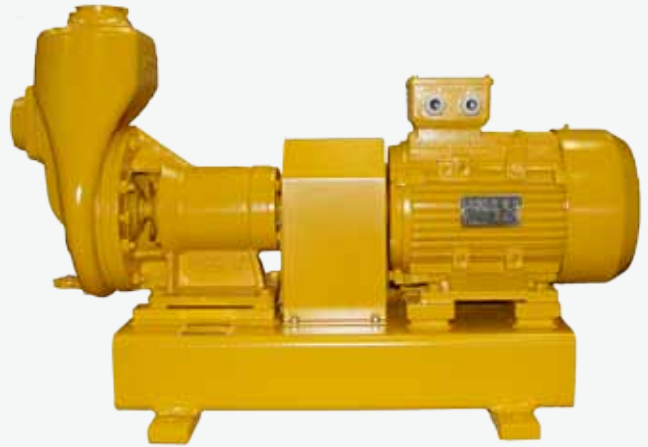

The pumps is used for many applications, for example:

- Bilge pumps
- Ballast pumps
- Fire pumps
- Cooling water pumps
- Wash-deck pumps
- Fuel pumps
- Wellpoint pumps
- Irrigation pumps
- Circulation pumps
- Etc.

Our engineers are experts, and their knowledge and experience, remain at your disposal.

If you are up against any pump problems which cannot be solved in applying the information from this leaflet, please contact us... we can help you!

Material specification

Materials	A	D
Pump casing	Cast Iron	Bronze
Impeller	Bronze	Bronze
Sealing ring	Bronze	Bronze
Rear cover	Cast iron	Bronze
Shaft	St. steel	St. steel
Shaft seal	Mechanical	Mechanical

Capacity range: 0-650 m³/h

Pressure range: 0-110 mLC

Temperature range:
With standard mech. shaft seal max. 80°C, with special mech. shaft seal max. 120°C.

Advantages

- Open impeller design
Semi-open, non clogging high efficiency impeller allowing the pump to operate on dirty water.
- Replaceable wear plate
To keep the pump at max. capacity even after working with abrasive fluids for a long time, the tolerance between impeller and wear plate may be adjusted by way of shims behind the replaceable wear plate.
- Mechanical shaft seal
A reliable, spring-loaded, mechanical shaft seal ensures rapid suction, and shaft wear and stuffing box tightening are avoided.
- Check valve mounted at a high level
The pump check valve is mounted well above the impeller inlet. Consequently, the pump will not - in case of a check valve leakage - lose the priming water which would result in a loss of priming ability.
- Heavy bearing design
Heavy shaft and bearing design provide long life even in case of belt drive.

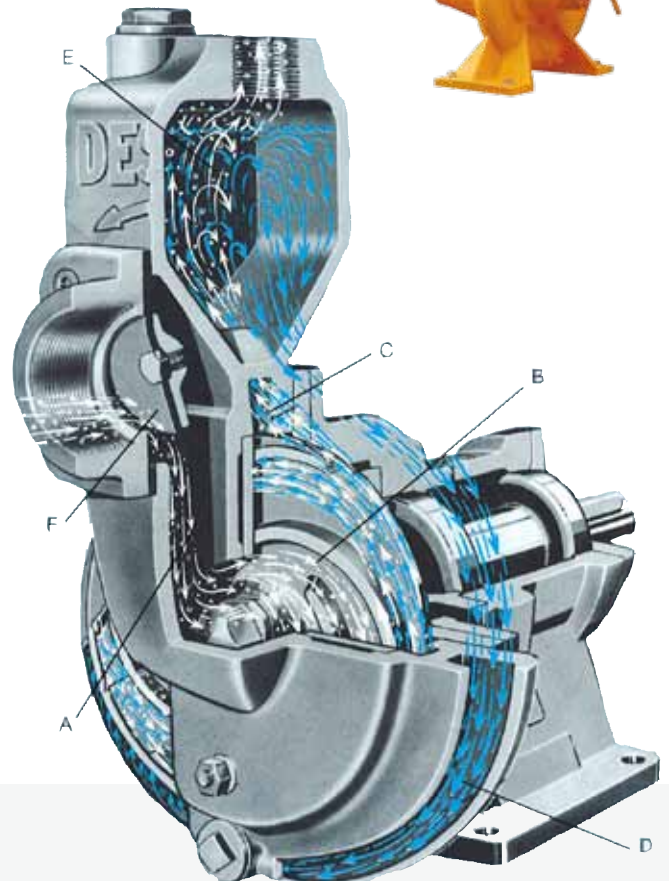

Operation Principle - Rapid and Safe Priming

The priming principle of the DESMI self-priming centrifugal pumps is based on the diffuser principle. This means that the priming capacity is not dependent on valves or other mechanical elements since it is the liquid flow which carries the air.

For priming, the pump casing is filled with liquid prior to starting. Due to the rotation of the impeller the liquid is immediately pumped from suction chamber A through impeller B into air separating chamber E.

Due to the negative pressure thus created in the impeller eye liquid is drawn through return passage D, into the impeller. Due to the negative pressure in the pump, check valve F opens so as to draw air from the suction line into the pump where liquid and air are mixed and proceed through passage C into air separating chamber E.

The water velocity of the air purging space is so low that the air is separated from the liquid, and the vented water carries on the circuit through the return passage and the impeller until the total air content of the suction pipe has been separated in space E.